

NRL
2000/3600
free-cooling

R410A

Air cooled chiller with axial fans
Cooling capacity from 446 kW to 904 kW



- **HIGH EFFICIENCY VERSION**
- **LOW NOISE HIGH EFFICIENCY VERSION**
- **PUMP ASSEMBLY OPTION**
- **4 REFRIGERANT CIRCUITS**
- **PUMP ASSEMBLY AND BUFFER TANK OPTION**

Characteristics

- Available in 7 sizes
- Refrigerant R410A
- 4 refrigerant circuits
- High efficiency even at part load
- Heat exchangers optimised to benefit from the excellent heat transfer characteristics of R410A
- High efficiency scroll compressors
- Axial fans with low sound level
- Solid construction with polyester anti-corrosion painted finish
- Operation up to 44° C ambient in cooling mode
- Operation modes:
 - Free-Cooling only: is the most economical way to use the unit. Only the fans operate by speed control. Cooling is achieved completely from the external air temperature
 - combined Free-Cooling and compressors: the cooling capacity is achieved from the external air temperature combined with compressor operation at full or partial load
- Versions available:
 - High efficiency
 - High efficiency low noise
 - Glycol free
 - With pump assembly (high head, with/without standby pump)
 - With pump assembly and 700 litre buffer tanks complete with water filter, flow switch, expansion tank, charging point and antifreeze electric heater
 - Electronic expansion valve
 - Inverter fans
- Microprocessor control system of the compressors and fans for the control of the three operating modes (Free-Cooling only, combined Free-Cooling and compressors, and compressors only)
- Display of all operating parameters in 4 languages.
- Simplified remote control panel located up to 50 m distance away with shielded cable. Permits basic control and alarm notifications of the unit
- High efficiency air-water coil (Free-Cooling) with smooth tubes and wavy fins
- Three-way valve installed on the hydraulic circuit to modulate flow to the Free-Cooling coils
- High and low pressure transducers (standard for all versions)
- Fan speed controller for low ambient operation. In Free-Cooling mode controls capacity.

Accessories

- **AER485P1:** RS-485 interface for supervision systems with MODBUS protocol.
 - **PGS:** Daily/Weekly Programmer. Allows two daily time-clock programmes (two switch on/off cycles) and different programmes for each day of the week.
 - **GP:** Protection grille protects the external coil from accidental damage.
 - **AVX:** spring anti-vibration mounts.
- Factory fitted accessory**
- **RIF** Power factor correction. Connected in parallel to the motor allowing about 10% reduction of input current. Must be requested at time of order and is available factory fitted only.
 - **PRM1 and PRM2:** FACTORY FITTED ACCESSORY. A manual reset pressure switch wired in series with the existing high pressure switch installed on the compressor discharge line.

Mod. NRL	Vers.	2000	2250	2500	2808	3008	3310	3600
AER485P1	All	• (x2)	• (x2)	• (x2)	• (x2)	• (x2)	• (x2)	• (x2)
PGS	All	•	•	•	•	•	•	•
GP	(1) All	260 (x2)	260 - 350	350 (x2)	350 (x2)	350 (x2)	500 (x2)	500 (x2)
	00	770	776	782	788	794	801	801
AVX	P3/P4	772	778	784	790	796	803	803
	03/04	771	777	783	789	795	802	802
Factory fitted accessory								
RIFNRL	All	2000	2250	2500	2808	3008	3310	3600
PRM1/PRM2	All	•	•	•	•	•	•	•

Unit Configurator

By suitably combining the numerous options available it is possible to configure each model in such a way as to meet even the most demanding of system requirements.

Configuration fields:

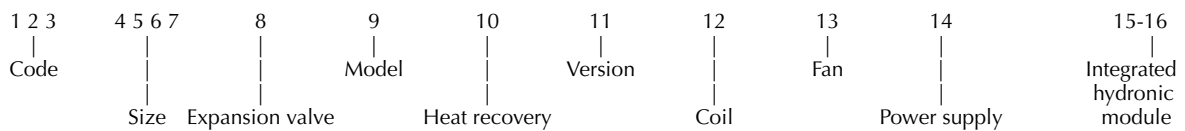

Code:

NRL

Size:

2000, 2250, 2500, 2808, 3008, 3310, 3600

Expansion valve:

- ° - Standard thermostatic expansion valve
- Y - Thermostatic expansion valve with leaving liquid temperature from +4°C down to -6 °C
- X - Electronic thermostatic valve, max. temp. of water produced: +4°C (for lower temperatures please contact us)

Model:

- F - Free-cooling
- B - Free-cooling glycol free

Heat recovery

- ° - Without heat recovery
- D - With desuperheater (partial heat recovery)

Version:

- A - High efficiency
- E - High efficiency low noise version

Coil:

- ° - Aluminium
- R - Copper
- S - Tinned copper
- V - Anti-corrosion coated aluminium (epoxy paint)

Fans:

- ° - Standard
- J - Inverter

Power supply:

- ° - 400V 3~ 50Hz with circuit breakers

Integrated hydronic module:

- 00 - without pump or buffer tank
- 03 - single high head pump and buffer tank
- 04 - single and standby high head pump and buffer tank
- P3 - single high head pump without buffer tank
- P4 - single and standby high head pump without buffer tank

WARNING:

The model "B" (Free-cooling, Free-cooling glycol free) glycol can not be provided with hydronic kit 03-04

Attention:

– the standard options are shown by the symbol °
 Example of configuration code: **NRL2000°F°A°°°00**

This is an NRL unit of size 2000, with standard thermostatic expansion valve, Free-cooling model, without heat recovery, high efficiency, with aluminium condenser coils, standard fans, and electrical panel for compressor motors 400V 3~ 50Hz, and without pump or buffer tank.

Technical Data

Mod. NRL	U.M.	Vers.	2000	2250	2500	2808	3008	3310	3600
Cooling capacity	kW	A	494	557	620	674	728	860	904
		E	456	517	578	620	662	800	842
Total power input	kW	A	206	217	228	272	314	318	350
		E	218	229	240	290	338	338	372
Water flow rate	l/h	A	84970	95800	106640	115930	125220	147920	155490
		E	78430	88920	99420	106640	113860	137600	144820
Total pressure drop	kPa	A	81	92	92	98	83	104	107
		E	69	80	80	84	70	90	93
EER	W/W	A	2,40	2,57	2,72	2,48	2,32	2,70	2,58
		E	2,09	2,26	2,41	2,14	1,96	2,37	2,26
Input current	A	A	389	403	417	504	592	597	634
		E	407	421	435	529	624	621	665
Cooling capacity	kW	A	458	486	514	582	652	798	880
		E	446	486	526	576	627	792	887
Total power input	kW	All	15	19	22	22	22	29	29
Water flow rate	l/h	A	85115	95903	106691	115871	125052	147870	155459
		E	78413	88871	99330	106518	113706	137540	144658
Total pressure drop	kPa	A	110	123	123	131	117	140	145
		E	94	107	107	111	97	122	126
EER	W/W	A	30,53	25,58	23,36	26,45	29,64	27,52	30,34
		E	29,73	25,58	23,91	26,18	28,50	27,31	30,59
Input current	A	A/E	30	37	44	44	44	59	59
Maximum current (FLA)	A	A/E	442	495	548	606	664	747	813
Starting current (LRA)	A	A/E	651	763	816	815	873	1015	1081
Compressors/circuits	n°/n°	A/E	8/4	8/4	8/4	8/4	8/4	10/4	12/4
Sound power	dB(A)	A	91,5	93,3	94,5	94,0	93,5	95,0	97,0
		E	85,5	87,3	88,5	88,0	87,5	89,0	91,0
Sound pressure	dB(A)	A	59,5	61,5	62,5	62,0	61,5	63,0	65,0
		E	53,5	55,3	56,5	56,0	55,5	57,0	59,0
Hydraulic connections	ø	All	3"	3"1/4"	4"	4"	4"	4"	4"
Air flow rate	m ³ /h	A	156000	193200	230400	228000	225600	310400	307200
		E	111600	136400	161200	159600	161400	217200	219600

Cooling mode

Evaporator water temperature (in/out) 12°C/7°C; Outdoor air temperature 35°C

Cooling in freecooling (100%)

Evaporator water temperature (in) 15 °C; Outdoor air temperature 2°C

Dimensions (mm)

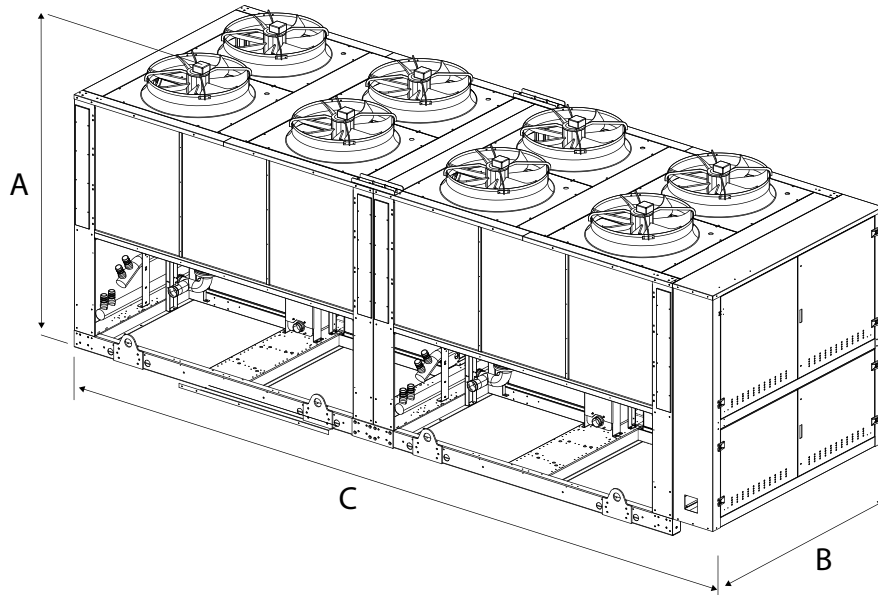

Mod. NRL-F / NRL-B	U.M.	Vers.	2000	2250	2500	2800	3000	3300	3600
Height	A (mm)	A/E	2450	2450	2450	2450	2450	2450	2450
Width	B (mm)	A/E	2200	2200	2200	2200	2200	2200	2200
Length	C (mm)	A/E	6400	7250	8100	8100	8100	11100	11100
Weight empty	(Kg)	A/E	5670	6190	6700	7120	7580	9060	9330